

WAKESPEED®

WS48-12x MANUAL



CHARGE  SMARTER



www.wakespeed.com



775.221.8898



support@wakespeed.com

OVERVIEW

Unlock next-level power capabilities with high energy systems. Experience lower costs, faster charging, and more real-world power availability. The Wakespeed 48v/12v Bi-Directional DC-DC Converter (WS48-12X) works in conjunction with a WS500 Advanced Alternator Regulator to simplify and streamline installations with its efficient bi-directional buck/boost DC-DC converter. From installation using the existing chassis alternator, to supplementing or even replace the chassis alternator with a high energy charging component, the WS48-12x seamlessly manages power distribution, putting it exactly where you need it.

- Seamless transfer of up to 3,000 watts of power from one voltage bus to the other.
- Support for 12v/48v power buses.
- Charge higher voltage batteries utilizing existing chassis electrical system.
- Works with existing chassis alternators - no 'add on' required.
- Dynamic power transfer regulation to match the capability of the chassis alternator – without overloading it.
- Optionally suppliant system power generation using 2nd 48v alternator fully controlled by the same WS500 for increased charging power.
- On demand supplemental chassis electrical system power to support surge loads without cost of additional batteries.
- J1939/RV-C based CAN support for system and BMS integration.
- Wide BMS integration support, both CAN and non-CAN based batteries.

TABLE OF CONTENTS

Safety Considerations	Page 3
Features	Page 4
Connections	Page 5
Mounting Orientation	Page 6
Wiring Harness Installation	Page 7
DC Wiring Installation	Page 9
Configuring with WS500	Page 10
Converter Performance	Page 12
Warranty Information	Page 13

SAFETY CONSIDERATION

The WS48-12X bidirectional converter is a part of a complex electrical system. A trained and licensed automotive or marine electrician is strongly recommended for its installation. Please note that an improperly installed electrical system component can result in severe damage to property and serious personal injury. Failure to properly install the WS48-12X bidirectional converter, the components wiring, or improper configuration may void the regulator's warranty in addition to damaging other system components. Wakespeed® is not liable for damage or injury resulting from improperly installed, configured, or modified applications of its products. The following safety precautions are recommended:



- Electrical and mechanical system installation or repair should NEVER be attempted when fatigued or while using alcohol or medication that can impair judgment or motor skills.
- Ensure that all jewelry and loose clothing is removed prior to work around engine or mechanical equipment.
- Use the proper tools per the installation requirements.
- Turn off switches and disconnect your batteries prior to installing your WS48-12X bidirectional converter or other electrical system components. Failure to do so may cause system damage or bodily injury.
- Ensure your alternator can provide the required current to charge your auxiliary battery bank.
- Read the manual!
- If you are not comfortable with the installation or operation of the charging system, please consider consulting a licensed and experienced technician to complete the installation.

FEATURES

The following list shows the main features of the WS48-12x.

SYSTEM VOLTAGE		BATTERY CHARGE PROFILES		COMPATIBILITY	
12v - 48v	Bidirectional power transfer from two power busses	CHARGE PROFILE	Preset and configurable profiles to match battery manufactures guidance	SYSTEM	Fully compatible with Wakespeed WS500 Advanced Alternator Controller
48v - 12v					
12v INPUT RANGE	8v to 16v (reduced capacity below 12v and above 15v)	CHARGE PHASE CRITERIA	Flexible charging protocol integrating: System voltage, Battery Acceptance Current, Battery Temperature, Alternator Temperature, and/or Time duration	BMS	Wide range of BMS integration supporting both CAN and non-CAN integration
48V INPUT RANGE	24v to 60v (reduced capacity below 48v and above 60v)				
ALTERNATOR SUPPORT		EXTENDED BATTERY TEMPERATURE RANGE SUPPORT		CONNECTIONS	
CHASSIS ALTERNATOR	12v	CONVERTER CAN BE CONFIGURED TO PROVIDE SAFE CHARGING OF BATTERIES OUTSIDE OF NORMAL TEMPERATURE RANGES BY DYNAMICALLY LIMITING CHARGE CURRENT.		SYSTEM	Multi-pin harness provides for system, optional alternator, CAN and BMS connection
HIGH ENERGY ALTERNATOR	48v				
DEPLOYMENT OPTIONS	12v Chassis Alternator	CONFIGURATIONS		POWER	12v: M10 48v: M8 Ground: M6
	48v High Energy Alternator	VIA APP	Full feature Wakespeed Application (Apple and Android) allows for simple configuration of alternator, battery, BMS and communication options.		
	Both 12v Chassis and 48v High Energy Alternators				
ALTERNATOR MANAGEMENT		COMMUNICATIONS		PROTECTIONS	
CHASSIS ALTERNATOR	No change needed. Alternator monitored for overloading and overheating	CAN	J1939 based CAN for system configuration, integration and monitoring.	12V	Reverse polarity, over current, short-circuit, under voltage and overvoltage protections
HIGH ENERGY ALTERNATOR	Full Management	PROTOCOLS	J1939, RV-C, Marine	48V	Reverse polarity, short-circuit, overcurrent, under voltage and overvoltage protections
TERMINAL MANAGEMENT		BMS PROTOCOLS	RV-C, SMA, Victron, LUX, Others	PHYSICAL AND ENVIRONMENTAL	
ALTERNATOR MONITORING	Both Chassis and High Energy Alternators are monitored and managed for overheating	USB	Diagnostics/configuration. Firmware upgrade.	DIMENSIONS	8.93" x 9.17" x 2.44" / 226.8mm x 233mm x 62mm
DC-DC CONVERTS	DC-DC converter scales back to prevent overheating.	FIRMWARE UPDATES		IP RATING	IP69K, IP67
		YES	Controller firmware updatable via built-in USB connector	OPERATING AMBIENT TEMPERATURE	-40°C to 75°C

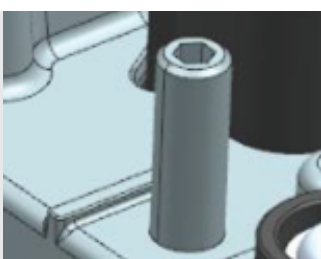
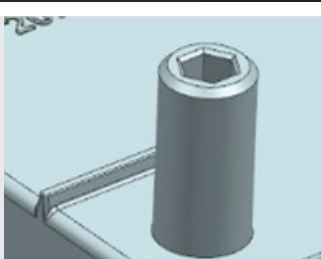
CONNECTIONS

<p>56V (48V) POS TYPE:</p>	<p>M8 Thread pitch: 1.25mm Torque: 8 [Nm] ±10%</p>	
<p>56V (48V) GND TYPE:</p>	<p>M6 Thread pitch: 1.0mm Torque: 8 [Nm] ±10%</p>	
<p>12V POS TYPE:</p>	<p>M10 Thread pitch: 1.5mm Torque: 16 [Nm] ±10%</p>	
<p>12V GND TYPE:</p>	<p>M12 Thread pitch: 1.75mm Torque: 40 [Nm] ±10%</p>	
<p>COM TYPE:</p>	<p>Communications and Power Port. Connect the wiring harness here.</p>	

MOUNTING ORIENTATION

The mounting orientation and the airflow direction should be applied according to mounting orientation 1, 2 or 3 as shown below.

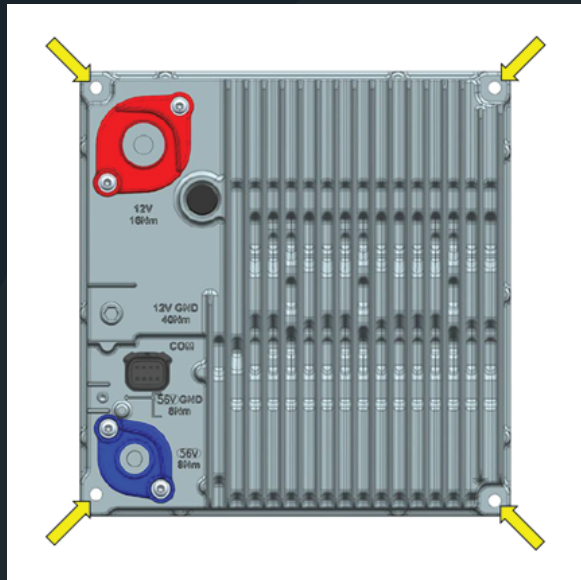

Hardware:

- Mount using M6 Flange head bolt according to DIN EN 1665 or similar
- Torque: 8 [Nm] \pm 10%

Active airflow will help promote optimal operation but is not required. If active air flow is opted for, direct the airflow across the cooling fins as shown below.

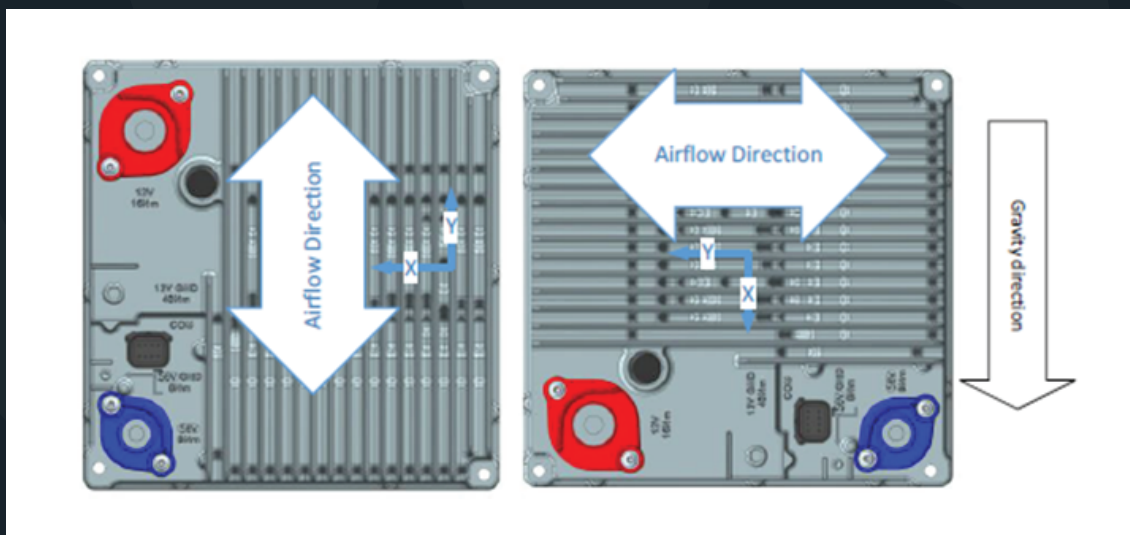

WIRING HARNESS INSTALLATION

The WS48-12X includes a high quality, industrial grade Ampseal connector system to provide a waterproof pairing between the WS500 regulator, harness, and WS48-12X bidirectional converter, along with sealed RJ45 connectors (via the WS500) for additional CAN bus system connection. The WS48-12X bidirectional converter is compatible with harness WSPHCAN and WSPH-VAN, which are CAN compatible WS500 harnesses.

This document will highlight the Harness installation specific for use with the WS48-12X bidirectional converter. For standard installation of the Wakespeed Regulator harness, please see the WS500 Alternator Regulator Product Manual.

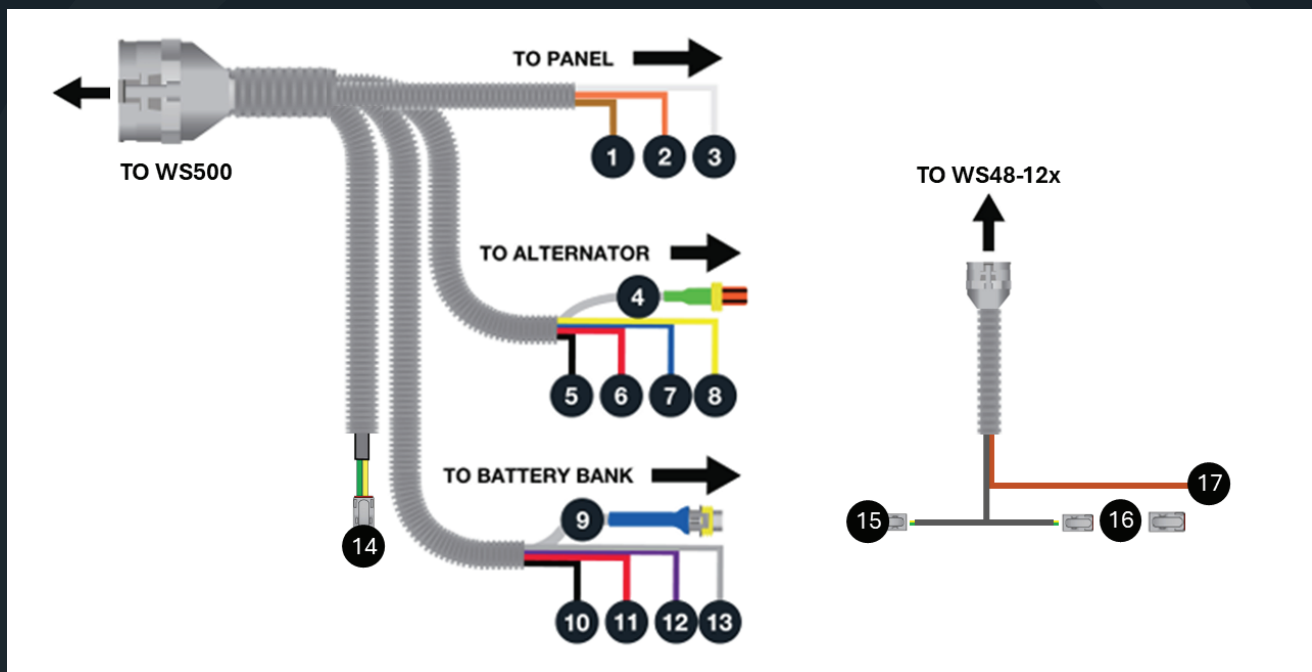

WS500 Harness Connections: WSPHCAN or WSPH-VAN

1. Ignition – The brown 16-gauge wire must see 8.5 volts or greater to turn on the WS500. Most often connect to a continuous DC power source to allow 24/7 control of the WS48-12X DCDC Converter.
2. Lamp – If not used. Cap off.
3. Function In – The white Function-In is often used connected to the Ignition to allow the WS500/WS48-12X combo to know if the chassis engine is running or not. A voltage > 8.5VDC signals the engine is running and excess power may be drawn from the chassis 12VDC system.
4. Alternator Temperature Sensor – Attach to the dedicated 48v alternator (If used). Optionally may be attached to the chassis 12v alternator or capped off and not used.
5. Alternator Negative – The black alternator negative must be connected to the negative post of the battery being charged. In multiple battery banks this wire should be instead connected to the Negative Bus-bar used to combine the multiple battery banks. If an optional dedicated 48v alternator is installed, the Alternator Negative may be connected either to the Battery negative, or the negative power post of the alternator.

6. Alternator Positive – The red positive wire must be connected to the positive post of the battery being charged. In multiple battery banks this wire should be instead connected to the Positive Bus-bar used to combine the multiple battery banks. If an optional, dedicated 48v alternator is installed, the Alternator Positive may be connected either to the Battery negative, or the negative power post of the alternator. In all cases, properly fuse the alternator Positive with a 10-15A/80v fuse. When fitting with an optional 48v alternator it is important to attach the Alternator Positive wire to the ‘alternator’ side of any potential charge bus disconnect: Fuse, Service Switch, etc. At all times the Alternator Positive need to be able to sense the actual Alternator voltage under all conditions.
7. Field – If installing the optional 48v alternator, connect this to the positive Field Post on that alternator. Else this is not used and should be properly sealed to prevent accidental shorting.
8. Stator (AC Tap) – May optionally be connected to either the 48v or 12v alternator ‘Stator’ output. If not used property seal to prevent accidental shorting.
9. Battery Temperature Sensor Terminal – The grey two-conductor cable is terminated with a Superseal-type connector which mates with the optional Battery Temperature Sensor. The battery temperature sensor enables the regulator to determine the temperature of the batteries, allowing for reduced charging rates as temperature extremes are approached, and charging cutoff as the battery reaches its defined charging temperature range: Too hot, or too cold.
10. Negative Battery Sense – The black with **yellow** tracer, wire must be connected to the negative post of the battery being charged. In multiple battery banks, should be connected to the battery Negative Bus-bar.
11. Positive Battery Sense – The **red** with **yellow** tracer positive wire must be connected to the battery being charged, or the positive Battery Bus bar in the case of a multi-battery installation. Properly fuse with a 3A/80V fuse. It is acceptable to use a common 10-15A fuse with the Alternator Positive wire if distances from the battery themselves are short.
12. Current Sense High – The **purple** wire connects to the “high” side of a current shunt. The default current shunt rating is 500A/50mV. See reference image on page 9 for details on which side of the shunt to connect depending on if the shunt is mounted in the batteries Ground or Power cable. In some installs where Battery Current is sensed remotely via CAN from the BMS and the Current Sense wires are not used, cap off the ends to prevent accidental shorting.
13. Current Sense Low –The **grey** wire connects to the “low” side of a current shunt. The default current shunt rating is 500A/50mV. See reference image on page 9.
14. CAN – The **green** and **yellow** twisted pair of wire provides communication between WS48-12X and WS500. Connect to the provided WS48-12x adapted cable.

WS48-12H Connections

15. CAN - The **green** and **yellow** twisted pair of wire provides communication between WS48-12X and WS500. Connect CAN to CAN of WS CAN Harness.
16. CAN Terminator – Connect to the included DTM CAN Terminator
17. Power – The **brown** wire connects to the positive 12v post of converter, providing power to the converter itself. Use 3A/40V or better fuse. Often connected to the same ‘power source’ as the **Brown** Ignition wire (1) of the WS500 harness. **CAUTION: Max 16V, DO NOT CONNECT TO 48V SOURCE!**

WIRING HARNESS DRAWING

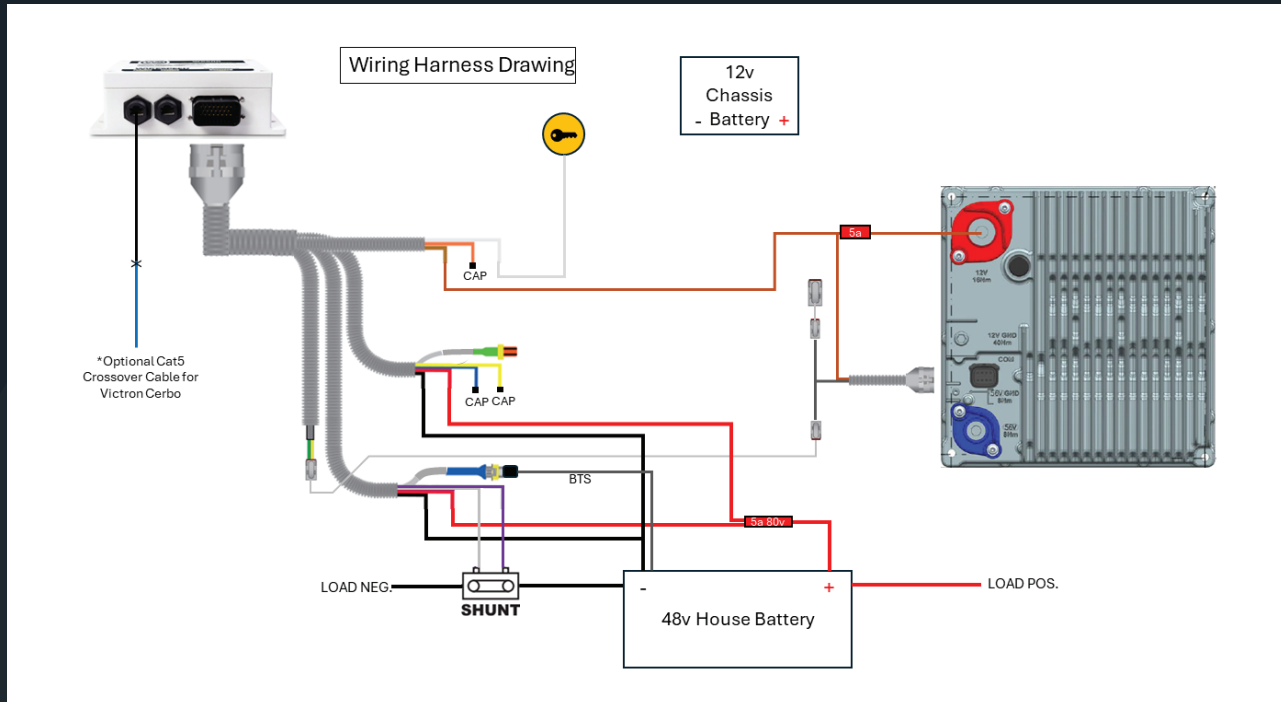

DC POWER WIRING DRAWING

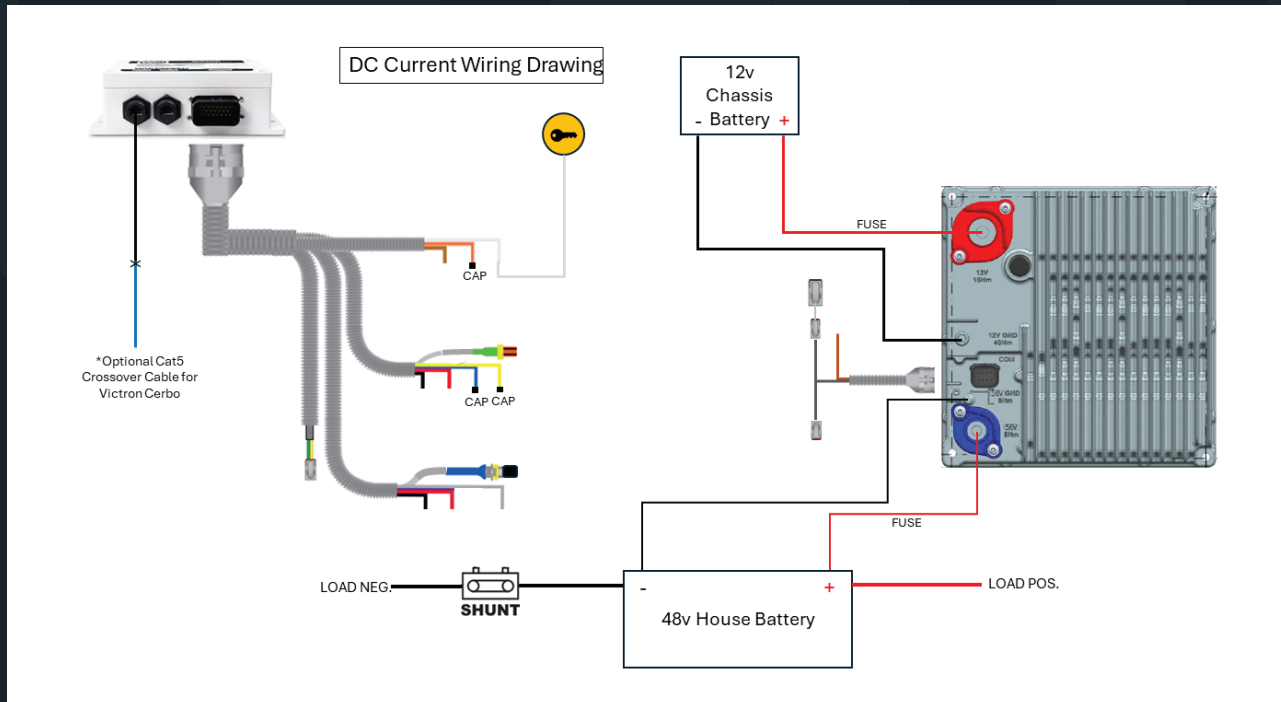

*Shunt may be mounted on positive or negative side of the 48v house battery bank.

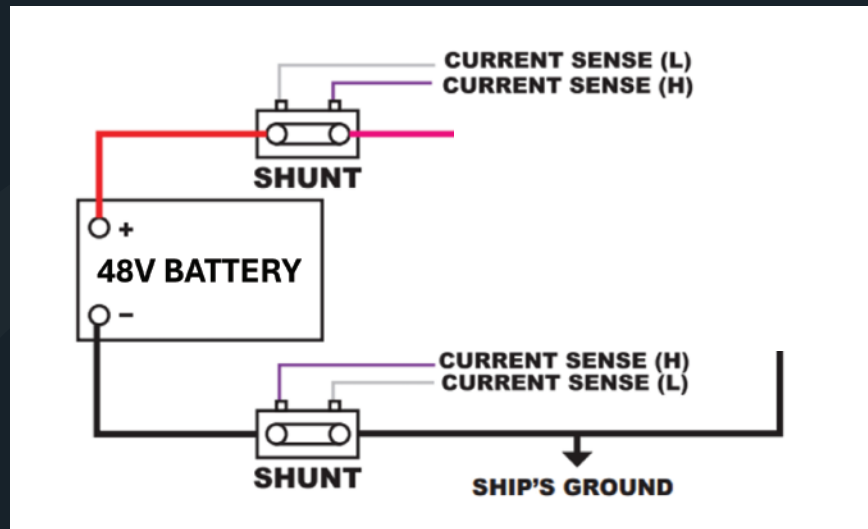

Note: Diagram is intended to indicate placement of current sense wires base on shunt location. Only one shunt is required for regulator operation.

CONFIGURATION

Using the Wakespeed App, updated to v1.9, configure your Alternator, Battery, BMS and system as you would normally. If a 48v Alternator is not being used, select 'None' / '48v' from the Make/Model options. Select the DCDC tab to configure the regulator for use with the WS48-12X converter.

- Select the WS48-12x model converter from the Model dropdown.
- Select the mode of operation. There are three modes of operation for the converter, which are explained below.

In **48v Battery Charging** mode the converter is used to transfer power from the 12v battery/alternator to help meet the charging needs of the 48v house battery the WS500 is primarily connected to. Note that if there is also a 48v Alternator the WS500 is controlling, both the alternator and the DC-DC converter will be managed to meet the battery charging needs.

In **12v Battery Support** mode, power is taken from the 48v battery and directed to the 12v battery. This might be for example when the vehicle has stopped and the engine is turned off. Power can be transferred from the 48v House battery down to the 12v 'starter' battery and any attached 2v legacy devices (Lights, Refrigerator, etc). In this way there is no need for a separate 12v house battery and all legacy 12v loads can be powered via the 48v battery without discharging the starter battery.

Dynamic mode intelligently manages between 48v Charging and 12v Support mode, directing power as needed and available between the two systems in real time.

In a typical application the WS500 is attached to the 48v house battery, with or without an associated alternator (also controlled by the WS500) and the 12v chassis battery with the chassis alternator.

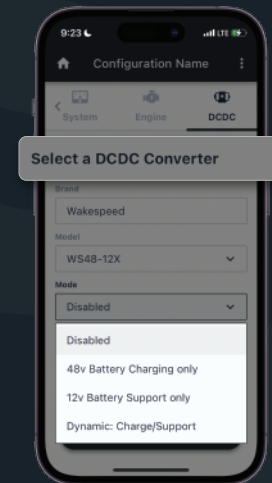

12v legacy loads (Room lights, 12v refrigerator, etc) are connected directly to the 12v starter battery (Perhaps with a Low Voltage safety cut-off) to complete a simple 12v House to more capably 48v house battery transition. The DC-DC converter is then configured to either charge the 48v battery using excess power from the 12v Chassis Alternator when the vehicle is running, or transfer power from the 48v house system to the 12v chassis system when the vehicle has stopped to support ongoing 12v loads. As a side benefit, the 12v chassis system is also provided with additional power when the vehicle is actually starting, to augment the existing starter battery with additional amps pulled from the 48v house battery.

Another configuration is where the chassis alternator is fully replaced with a 48v alternator. By enabling only 12v Support the DC-DC converter can emulate a 12v alternator, recharging the starter battery after starting the vehicle as well as suppling power for all ongoing chassis needs beyond any legacy 12v loads.

After selecting the Mode of operation for the WS48-12x converter, the Control Setpoints must be defined.

Engine Running Voltage Control Value

- When the vehicle's engine is running, the voltage of the 12v chassis should increase to a value higher than the resting voltage of the starter battery. The default value is 13.4v, but fine tuning of this value may be required depending on your specific vehicle.
- Select a value to maximizes power transfer from the chassis 12v alternator to the 48v battery system without placing undue stress on the 12v system. You may also have to adjust the value to accommodate any engine checks and ECU expectations, being careful if the voltage value is too low. Use this in conjunction with the 12v Battery Amperage Limits defined below to fine tune your install.

Engine Stopped Voltage Control Value

- When the vehicle's engine is turned off, we can expect the voltage of the 12v chassis to decrease to the resting voltage of the starter battery. The default value is 12.4v, but fine tuning of this value may be required based on the starter battery manufacturers recommendations.
- Select a voltage that keep the starter battery charged, but does not have the WS48-12x consistently on, thereby wasting energy. A slow cycle on/off and then turning on when a 12v load is applied will give the best results.

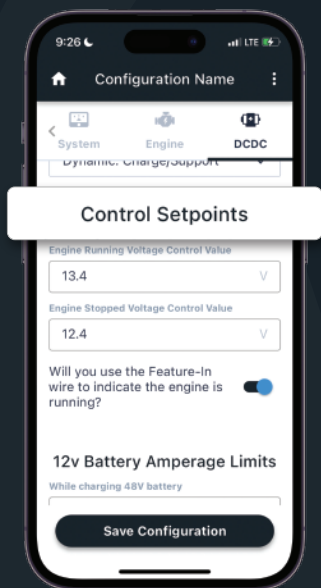

Next, you will need to verify and/or adjust the 12v Battery Amperage Limits.

While charging 48v battery

- This is the maximum current allowed to be drawn from the 12v DC system while charging the 48v battery bank.

While supporting 12v battery

- This is the maximum current into the 12v DC system while supporting 12v loads.

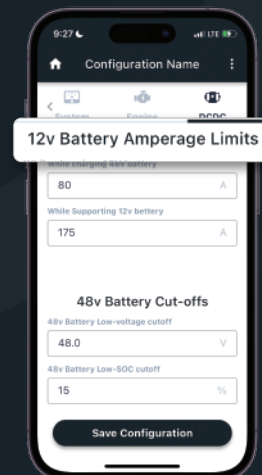

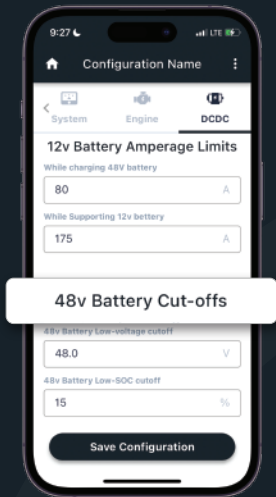

Next, you will need to define the 48v Battery Cut-offs.

48v Battery Low Voltage cutoff

- When in 12v support mode (or Dynamic), this value is the voltage setpoint to which the converter will stop supporting the 12v loads due to the 48v battery bank falling below this value. Please use 48v battery manufacturer's recommendation for Low Voltage limits.

48v Battery Low-SOC cutoff

- When using a 48v battery capable of communicating states of charge to the WS500, this value will provide a defined depth of discharge as to not deplete the 48v battery. Note that a CAN connected BMS is required which supplies batter SOC for this cutoff to be followed.

CONVERTER PERFORMANCE

Performance derating applied on the 12v input voltage, as shown below:

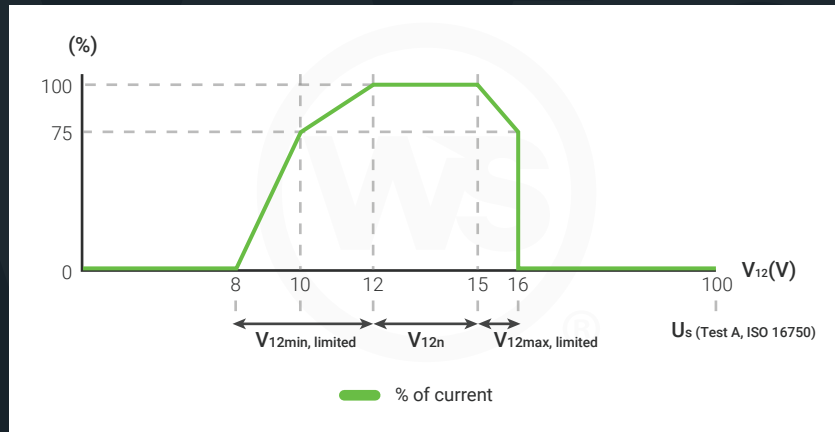

Performance derating applied on the 48v input side, as shown below:

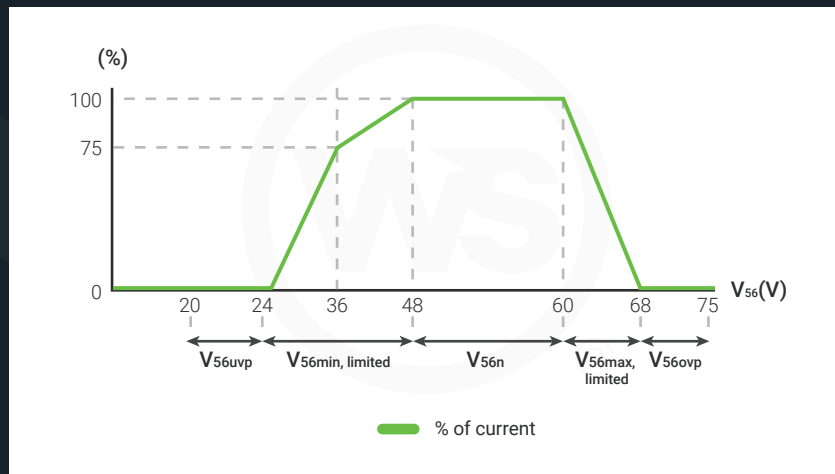

TWO YEAR LIMITED WARRANTY

The manufacturer warrants the Wakespeed 48v/12v Bi-Directional DC-DC Converter (WS48-12x) product shall meet specifications and be free from any defects which appear therein under proper use, which arise solely from faulty materials or workmanship for a period of two (2) years from the original date of purchase. This Limited Warranty is only valid for the original purchaser and is non-transferable. The Warranty Period is not extended if we repair or replace the product.

THIS LIMITED WARRANTY GIVES YOU SPECIFIC LEGAL RIGHTS AND YOU MAY ALSO HAVE OTHER RIGHTS, WHICH VARY FROM STATE TO STATE. A LINK TO THE LIMITED WARRANTY CAN ALSO BE FOUND IN THE DOCUMENTATION WE PROVIDE WITH THE PRODUCT. WE WARRANT THAT DURING THE WARRANTY PERIOD, THE PRODUCT WILL BE FREE FROM DEFECTS IN MATERIALS AND WORKMANSHIP.

WE LIMIT THE DURATION AND REMEDIES OF ALL IMPLIED WARRANTIES, INCLUDING WITHOUT LIMITATION THE WARRANTIES OF MERCHANTABILITY AND FITNESS FOR A PARTICULAR PURPOSE TO THE DURATION OF THIS EXPRESS LIMITED WARRANTY. SOME STATES DO NOT ALLOW LIMITATIONS ON HOW LONG AN IMPLIED WARRANTY LASTS, SO THE ABOVE LIMITATION MAY NOT APPLY TO YOU.

OUR RESPONSIBILITY FOR DEFECTIVE GOODS IS LIMITED TO REPAIR OR REPLACEMENT AS DESCRIBED BELOW IN THIS WARRANTY STATEMENT.

Defects or physical damage resulting from abuse, neglect, accident, improper repair, alteration, modification, or unreasonable use of the products are not covered under warranty. Returned products showing evidence of tampering and/or unapproved access to internal components will not be supported under warranty. This warranty does not cover: (a) any defects sustained by normal wear and tear; (b) any defects arising in consequence of negligence or improper handling or use of the product or parts thereof by the customer; (c) any defects arising of maintenance by unauthorized persons or third parties; (d) any defects due to improper storage in the event the product wholly or partly being stored by the customer prior to installation or use; (e) any defects arising in consequence of external influences, environmental or stress testing or unilateral adjustments to the specifications by the customer on the use of the products or parts incorporating the product; (f) any defects arising from combination of the product with other hardware or software.

The manufacturer cannot warranty broken cases, parts damaged by fire, water, freezing, collision, theft, explosion, rust, corrosion, damaged cables or wiring harnesses, or items damaged in shipment in route to manufacturer for repair. Manufacturer assumes no responsibility for consequential damage or loss or expense arising from these products or any labor required for service or repair.

Manufacturer's liability with respect to the Wakespeed 48v/12v Bi-Directional DC-DC Converter (WS48-12x) product under this warranty shall be to supply replacements of such parts of the product as have proved to have such defects as set out here above or, at manufacturer's option, repair such parts or have them repaired at manufacturer's order, provided that we are informed by the customer in writing within thirty days after the defects have revealed themselves and the defective product has been placed at manufacturer's disposal; the defective parts shall become manufacturer's property as soon as they have been replaced.

The manufacturer will not repair or be held responsible for any product sent without proper identification and return address. Customers must include proof of date and place of purchase or manufacturer cannot be responsible for repairs or replacement.

We may change the availability of this Limited Warranty at our discretion, but any changes will not be retroactive.

Repair or replacement of the defective part or product is to be supplied free of charge upon delivery of the defective product to manufacturer. Customer is responsible for all the cost of return shipping and handling, any related claims that may arise., and any air, international or rush delivery expense.

LIMITATION OF LIABILITY

THE REMEDIES DESCRIBED ABOVE ARE YOUR SOLE AND EXCLUSIVE REMEDIES AND OUR ENTIRE LIABILITY FOR ANY BREACH OF THIS LIMITED WARRANTY. OUR LIABILITY SHALL UNDER NO CIRCUMSTANCES EXCEED THE ACTUAL AMOUNT PAID BY YOU FOR THE DEFECTIVE PRODUCT, NOR SHALL WE UNDER ANY CIRCUMSTANCES BE LIABLE FOR ANY CONSEQUENTIAL, INCIDENTAL, SPECIAL OR PUNITIVE DAMAGES OR LOSSES, WHETHER DIRECT OR INDIRECT. SOME STATES DO NOT ALLOW THE EXCLUSION OR LIMITATION OF INCIDENTAL OR CONSEQUENTIAL DAMAGES, SO THE ABOVE LIMITATION OR EXCLUSION MAY NOT APPLY TO YOU.



TM